

STEEL AND PIPE SUPPLY

de México S de. R.L. de C.V.

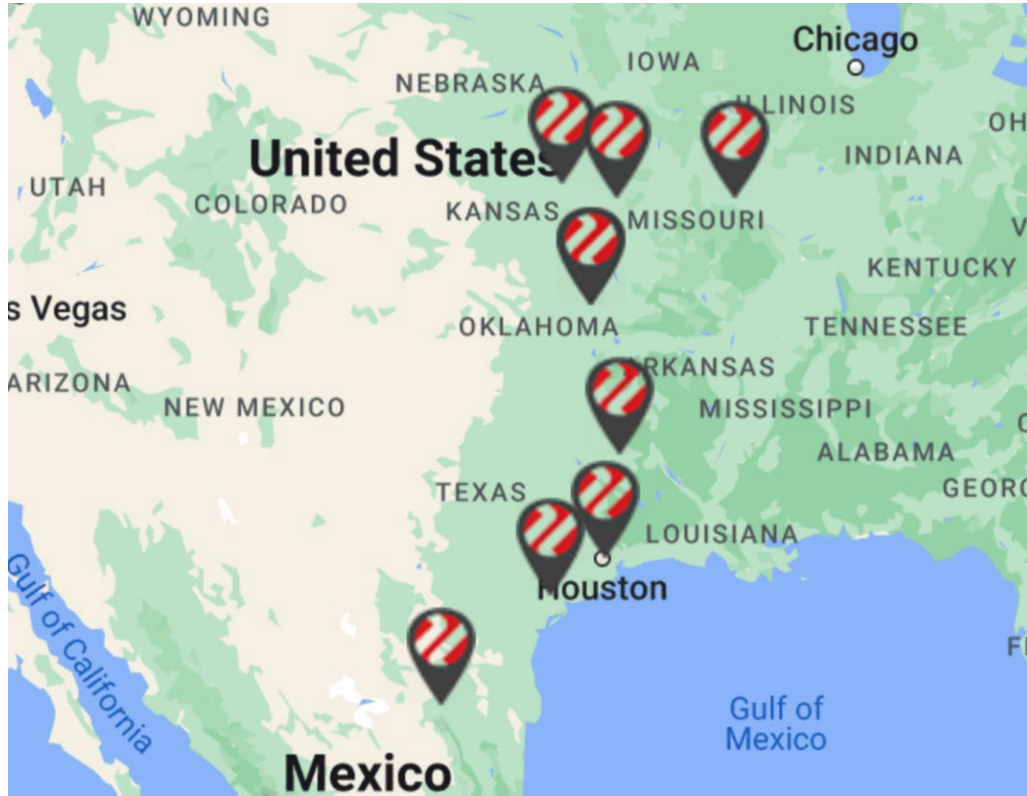

Steel and Pipe Supply



- Headquartered in Manhattan, Kansas
- 68+ years in the Steel industry
- 1200+ employees, 13 business units
- Strong financials
- Relationships with mills worldwide



Steel Transformation

Processing

- Stretcher Leveling: Cut to Length
- Laser (2x4 mts)
- Press Brake (4mts x 320 tons)
- Plasma (Downdraft 120" x 720" and water 144" x 600")
- Shear
- Bandsaw
- Roller Bending
- Slitter



Steel Transformation

Stretcher Leveler



- ◉ Min THK: 16GA (.0673") W:36" L: 50"
- ◉ Max THK: .500" W: 96" x L: 800" 80 KSI YIELD
- ◉ Up to 30 tons per coil
- ◉ OD 40" - 80"
- ◉ ID 20" - 31"
- ◉ Capacities for P&O roll is from 14ga (0.747")

Steel Transformation (Laser)

2 BLM Laser beds with automation

8 KW, 4x2 mts (13' x 6.5')

- Max THK 1/2" Nitrogen
- Max THK 1-3/16" Oxygen



Steel Transformation (Press brake)

3 Brakes (4mts, 4mts, 3mts)

- Up to 7mts Long
- Max: 320 tons



Steel Transformation

Plasma / Oxycut



Hypertherm 400XD

- Plasma: 2" x 120" x 720"
- Oxycut: 3-1/2" x 120" x 720"

Altra 260XD

- Plasma: 1-1/2" x 144" x 600"
- Oxycut: 5" x 144" x 600"

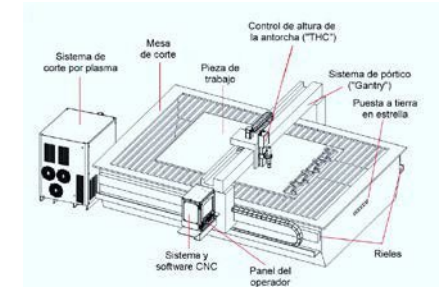

Roller Bender



Durma roller

- 1/2" thickness x 120" wide

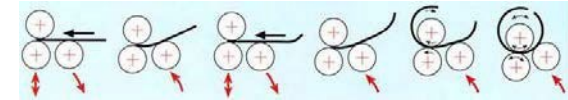

Steel Transformation

Shear



- ½" thick – 48" back gauge 120" wide

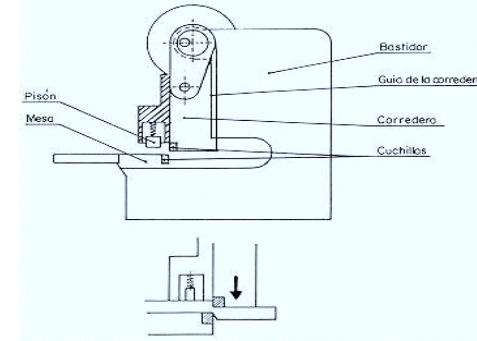

Bandsaw



- Up to 26" x 26" x length

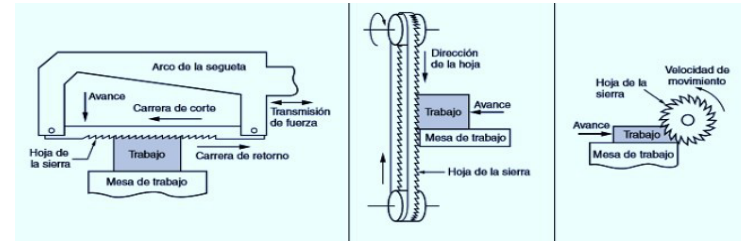



CERTIFICATE

Certificate Registration No: 951 17 7317

The Certification Body of TÜV SÜD AMERICA INC.

Certifies that the organization



Steel and Pipe Supply de México, S. de R.L. de C.V.
Arq. Pedro Ramírez Vázquez, No. 200-11, piso 10, Colonia Valle Oriente
San Pedro Garza García, Nuevo León, 66269 Mexico

for the scope

Marketing, Processing and Storage of Steels such as Sheets, Plates, Rolls, Beams, Angles, Bars, Channels, Tubes, and Steel Processing such as Shape Correction (Memory Clear Operation), Long and Wide Roll Cutting, Plasma Cutting, Oxyfuel, Laser Cutting, Band Sawing, Cutting with Shears, Formed, Bending, and Cleaning of Steels for Various Industrial Sectors

Including the sites see enclosure

has established and applies a Quality Management System.
An audit was performed and has furnished proof that the requirements according to

ISO 9001:2015

are fulfilled.

The certificate is valid from September 14, 2023 until June 5, 2026
With a re-issue date on September 19, 2023

Greg Bates
Director Business Assurance America
Page 1 of 2



Steel and Pipe Supply de Mexico

Monterrey Office

Arq. Pedro Ramirez Vázquez 200-11 piso 10 Col.
Valle Ote.
San Pedro Garza Garcia, Nuevo León México,
C.P. 66269

Escobedo NL - Warehouse

Libramiento Noreste KM 27.5 Escobedo
Nuevo León México, C.P. 66050

Sales contact

Oscar Garza

oscar.garza@steelandpipe.com

Tel: 811 516 7313

